

PDCN	REV.	APPV DATE	REVISIONS	DWN	DSGN	CHK	APPV
2006318	A	10/06/06	INITIAL ISSUE	RSR	AA	DRL	AA
			FIELD CDIL PART NUMBER: 0432-6340 WAS 0432-6040				

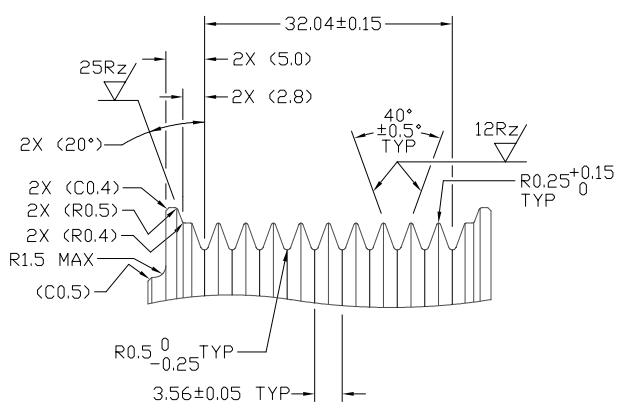

DETAIL B
SCALE 2:1

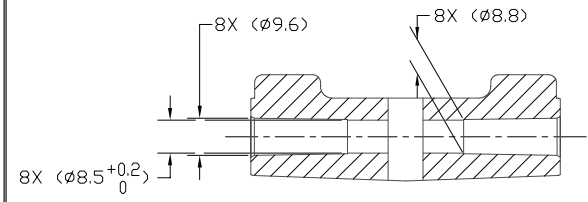

SECTION A-A

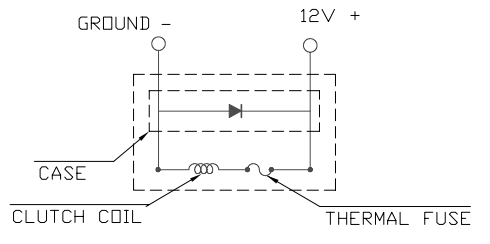

CIRCUIT DIAGRAM
(FOR REFERENCE)

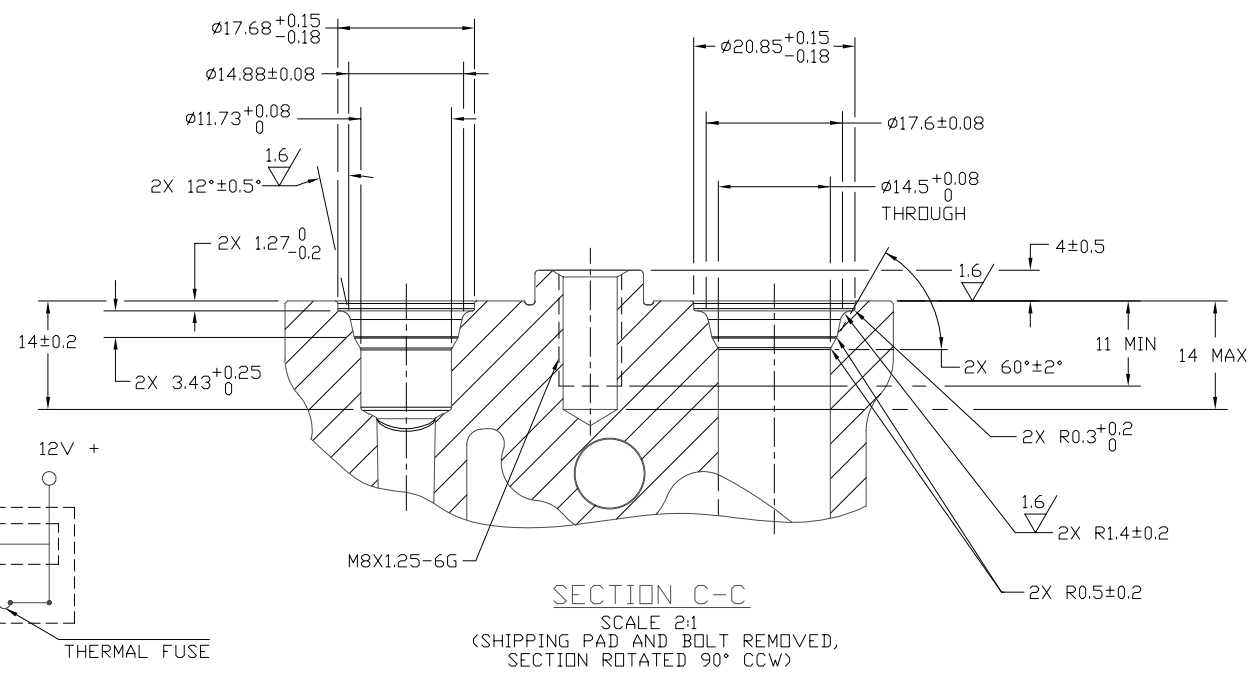

SECTION C-C
SCALE 2:1
(SHIPPING PAD AND BOLT REMOVED,
SECTION ROTATED 90° CCW)

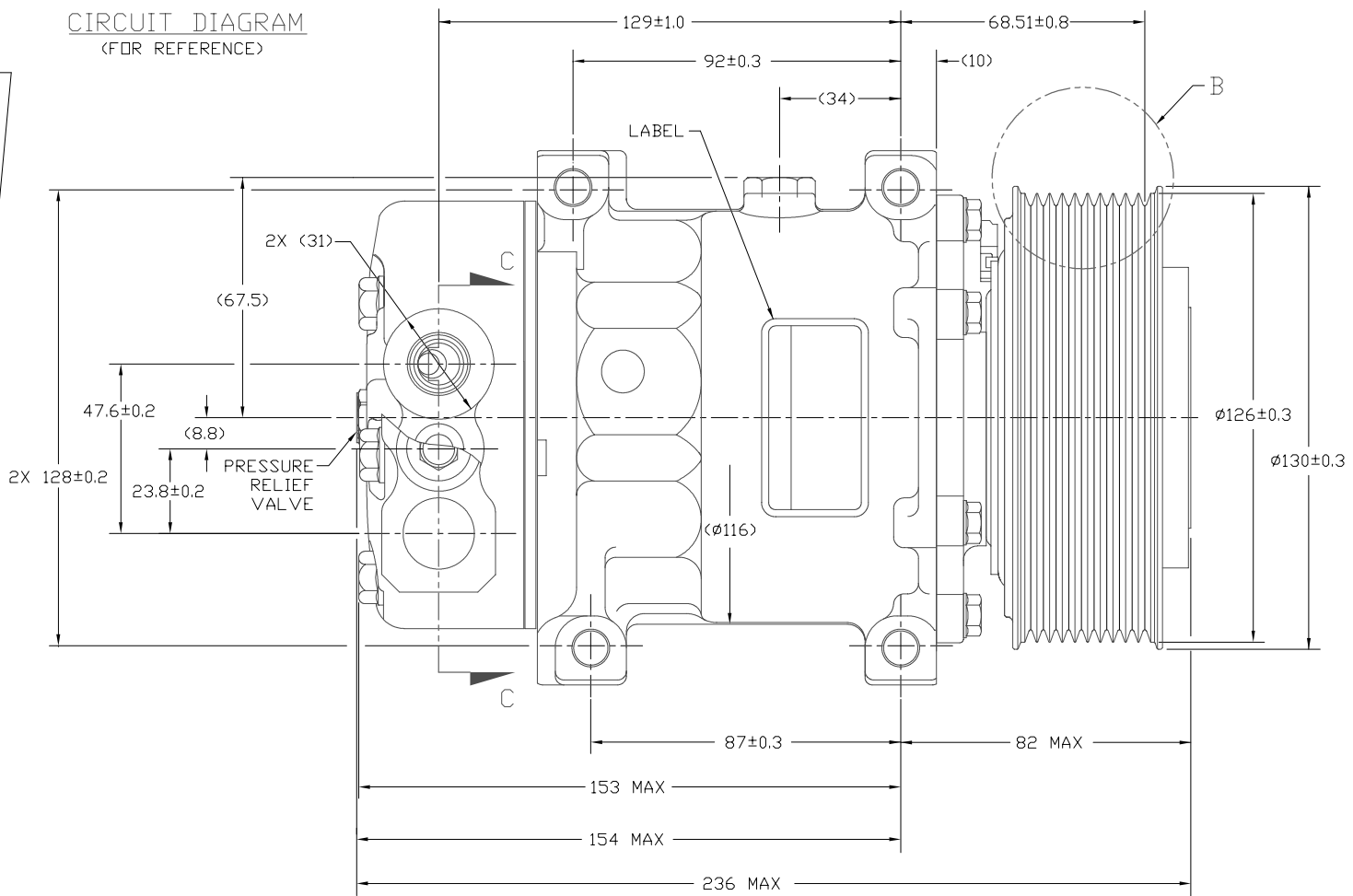

CLUTCH SPECIFICATIONS (REF)

RATED VOLTAGE	DC 12V
BREAKAWAY TORQUE	3.5 kgf-m min. @ 12V
MINIMUM ENGAGEMENT VOLTAGE	7.5V @ AIR GAP 0.6mm
POWER CONSUMPTION	49 watts max.
BELT TYPE	PV10 TYPE
MAXIMUM ALLOWABLE BELT TENSION	120 kgf
PULLEY DIAMETER	ø126 mm (4.96 in.)
CLUTCH TYPE	HEAVY DUTY

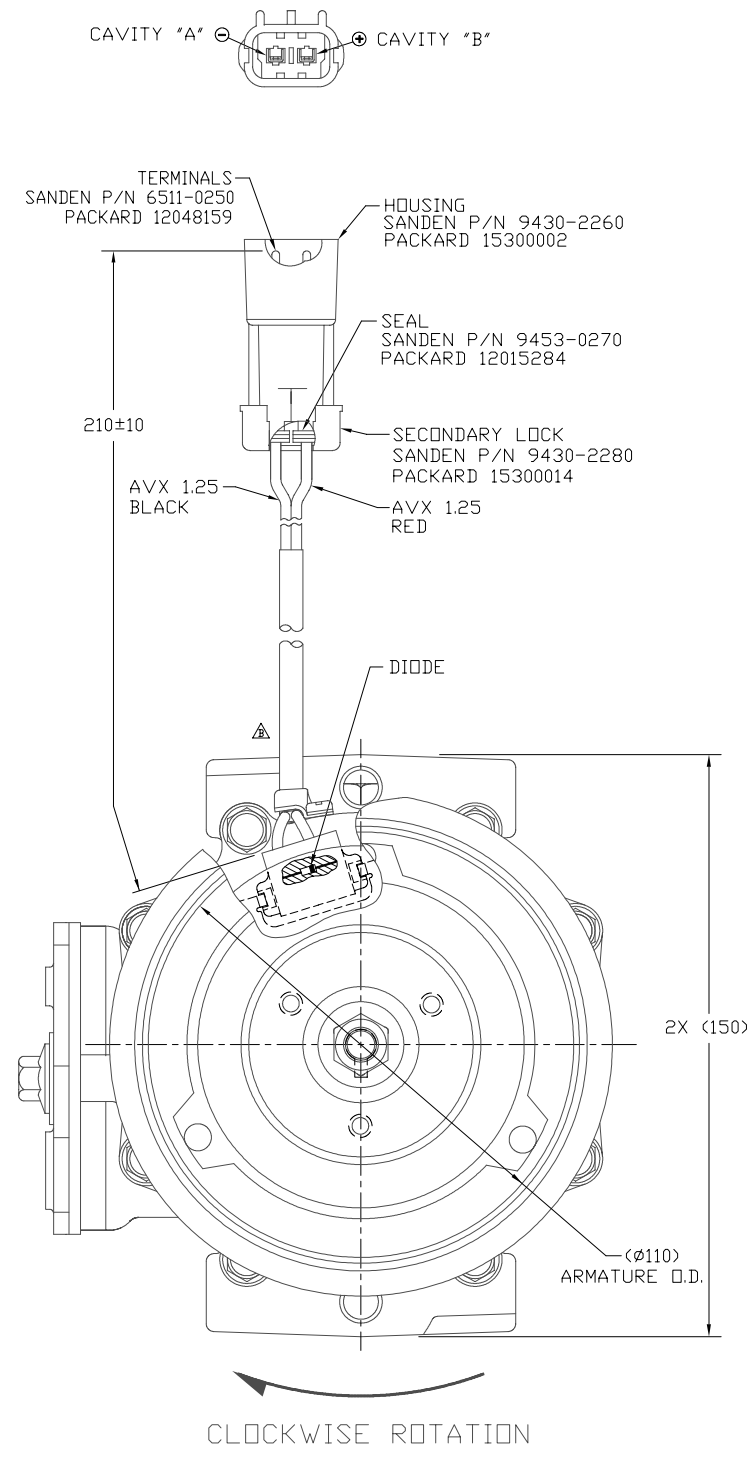

COMPRESSOR SPECIFICATIONS (REF)

DISPLACEMENT PER REVOLUTION	154.9 cc / rev. (9.5cu.in. / rev.)
MAXIMUM ALLOWABLE R.P.M.	8000 R.P.M.
MAXIMUM ALLOWABLE CONTINUOUS R.P.M.	6000 R.P.M.
REFRIGERANT	R134a
OIL (SP-15)	300 cc (10.1 fl.oz.)

- NOTE:
- DIMENSIONS ARE TO VIRTUAL SHARP CORNERS UNLESS OTHERWISE SPECIFIED.
 - COMPRESSOR TO BE CHARGED WITH NITROGEN PRIOR TO SHIPPING WITHIN 0.2 TO 1.6 kg/cm².

DO NOT SCALE

REV. LEVEL	RELEASED FOR: ENGG. DEVELOPMENT	<p>SANDEN INTERNATIONAL (U.S.A.), INC.</p>	<p>DRAWN SCALE REF 1:1 PLOTTED SCALE REF 1:1 METRIC</p>
DWN	J Sokolowski		
CHK	Dennis Lee 9/19/06	<p>This drawing and the information contained hereon are CONFIDENTIAL and PROPRIETARY to Sanden International (U.S.A.), Inc., and are received in CONFIDENCE and shall not be used, copied, or disclosed to others without the written permission of Sanden International (U.S.A.), Inc.</p>	<p>INTERPRETATION OF THIS DRAWING PER ASME Y14.5M-1994</p>
APPV. DATE	Alferdo Armendariz 9/19/06		
REV. LEVEL	RELEASED FOR: DESIGN VALIDATION	<p>THIRD ANGLE PROJECTION</p>	<p>SIZE D</p>
DWN	Alferdo Armendariz		
APPV. DATE	Alferdo Armendariz 9/19/06	<p>MATERIAL:</p>	<p>NAME</p>
REV. LEVEL	RELEASED FOR: PRODUCTION VAL'D.		
DWN	Alferdo Armendariz	<p>4384-6000</p>	<p>REV B</p>
APPV. DATE	Alferdo Armendariz 9/19/06		
REV. LEVEL	RELEASED FOR: PRODUCTION		
DWN	Alferdo Armendariz		
APPV. DATE	Alferdo Armendariz 9/19/06		
REV. LEVEL	RELEASED FOR: PRODUCTION		
DWN	Alferdo Armendariz		
APPV. DATE	Alferdo Armendariz 9/19/06		